

THIS DRAWING IS UNPUBLISHED. RELEASED FOR PUBLICATION 20
 © COPYRIGHT 20 BY - ALL RIGHTS RESERVED.

REVISIONS				DATE	DWN	APVD
P	LTR	DESCRIPTION				
B2		REVISED PER ECR-15-013268	10SEP2015	NK	GJ	

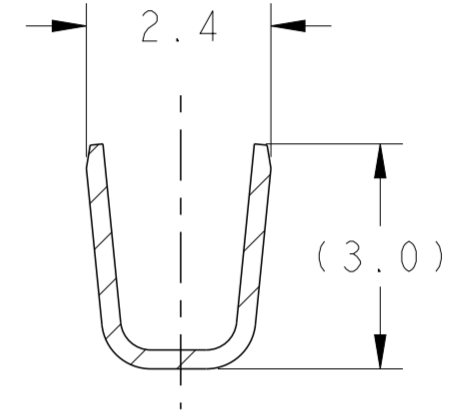

SECTION C-C

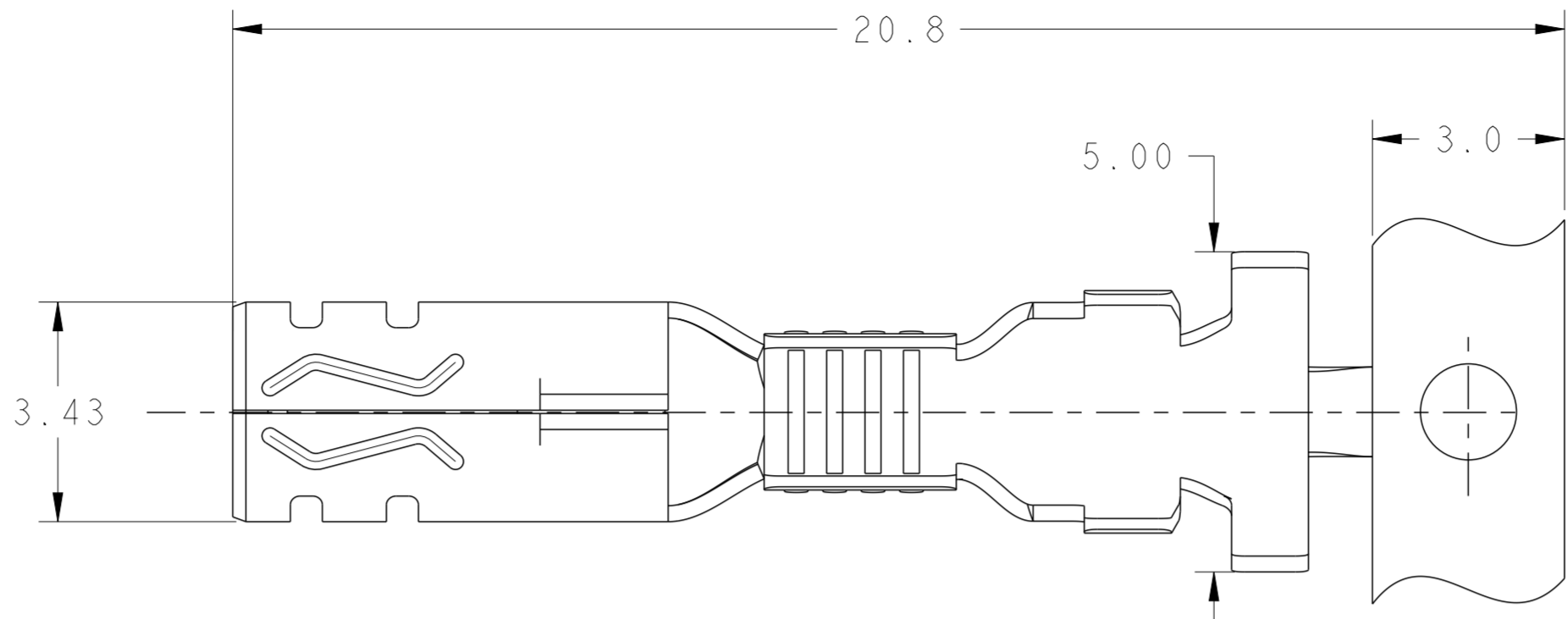
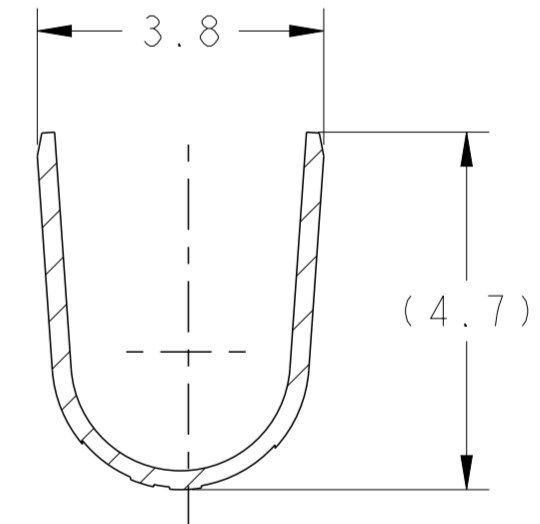
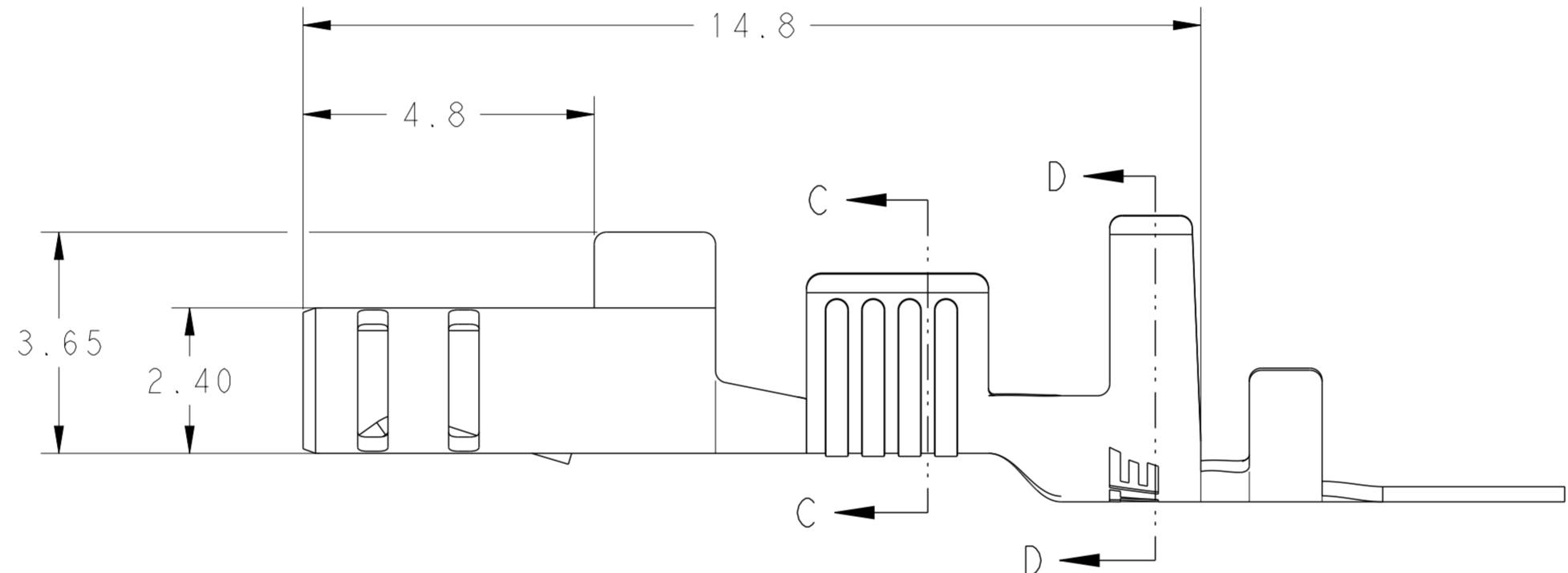

SECTION D-D

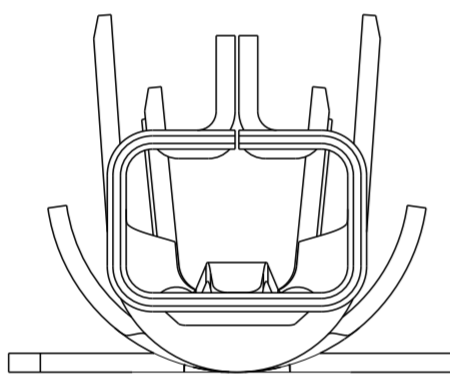

- 1 APPLICABLE WIRE RANGE: 16~20AWG COPPER STRANDED OR 2x 22AWG COPPER STRANDED. FOR A #20 AWG WIRE THE RECOMMENDED MINIMUM CROSS-SECTIONAL AREA IS 0.65mm² (1300 CMA).
- 2 FOR #20 AWG WIRE WITH AN AREA/CMA SMALLER THAN INDICATED ABOVE, RECEPTACLE 1971785-() IS RECOMMENDED.
- 3 APPLICABLE INSULATION DIAMETER: 2.40~3.30mm. 2.00~3.30mm(2.0 mm MAX FOR 2x 22AWG) WHEN AN OVERLAP INSULATION APPLICATOR IS USED.
- 4 APPLICABLE MATED PLUG HOUSING P/N:
 -1971773-/*-1971776-*/*-1971876-*/
 -2232265-/*-2232266-*/*-2232357-*

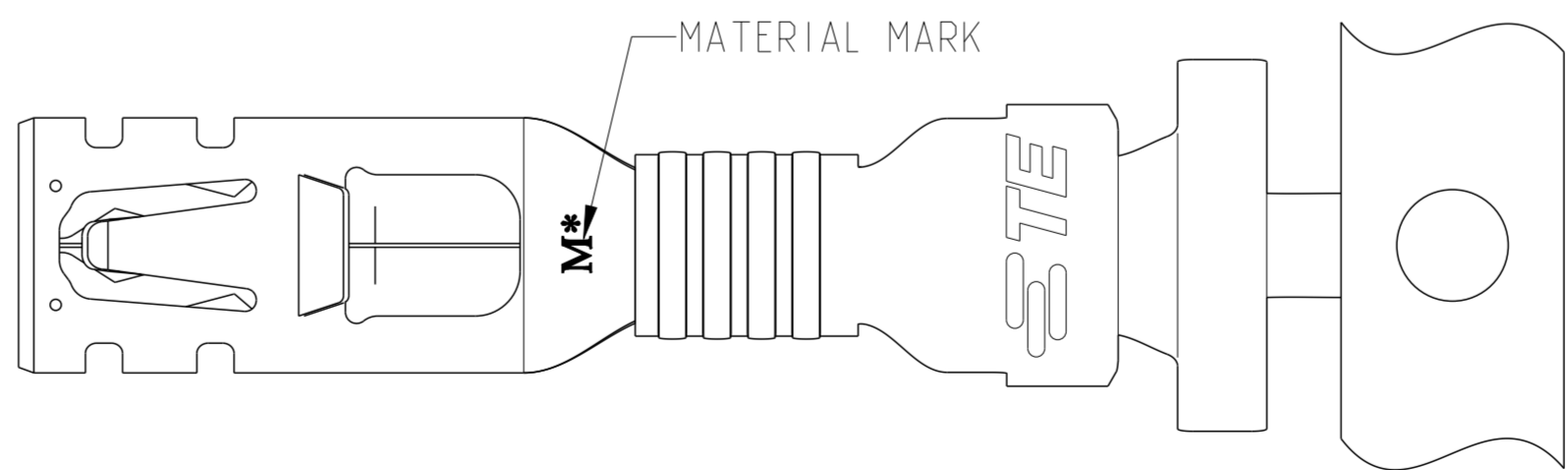

5 THIS PRODUCT HAS NOT COMPLETED VALIDATION TESTING.

MATERIAL	TEMP. RATING	MATERIAL MARK	PART NO
COPPER ALLOY	HIGH(150°C)	M0	1971783-2
PHOS BRONZE	STANDARD(105°C)	M1	1971783-1

THIS DRAWING IS A CONTROLLED DOCUMENT.

DIMENSIONS: mm	TOLERANCES UNLESS OTHERWISE SPECIFIED: 0 PLC ± 0.5 1 PLC ± 0.30 2 PLC ± 0.30 3 PLC ± 0.30 4 PLC ± 0.30 ANGLES ± FINISH	DWN TOMMY WU 11JUL2012 CHK HAPYE WU 11JUL2012 APVD YUHONG MAO 11JUL2012 PRODUCT SPEC 108-106118 APPLICATION SPEC 114-106118 WEIGHT -	NAME RECEPTACLE CONTACT POWER TRIPLE LOCK
MATERIAL SEE TABLE	PRE-TIN	SIZE A2 CAGE CODE 00779 DRAWING NO. 1971783	RESTRICTED TO -
Customer Drawing		SCALE -	SHEET 1 OF 1 REV B2